

FM PARTEC®

FM Partec S.p.A. - Via Europa 4 - Correggio (RE) Italy
Tel (+39) 0522 631055 - info@fmpartec.com

USE AND MAINTENANCE MANUAL

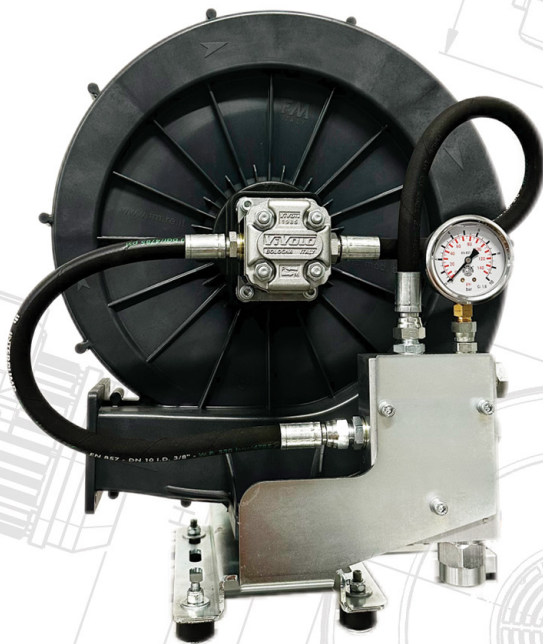

GREENBLOW HYDRAULIC without drainage with valve

GREENBLOW®

ASSEMBLY INSTRUCTIONS (ORIGINAL IN ITALIAN)

PRODUCT: GREEN BLOW HYDRAULIC

Read the instructions carefully and keep them for future reference, referring to the FM PARTEC technical specifications contained in the catalogue. If you are not in possession of these specifications, please ask for them to be provided.

1 TABLE OF CONTENTS

1		TABLE OF CONTENTS	Pag.	1
2		FIELD OF APPLICATION	Pag.	2
	2.1	DESCRIPTION	Pag.	2
	2.2	COMPONENTS	Pag.	2
	2.3	INTENDED USE	Pag.	2
	2.4	OPERATING LIMITS	Pag.	3
	2.5	PROHIBITED USE	Pag.	3
	2.6	SAFETY	Pag.	4
3		TECHNICAL FEATURES	Pag.	5
4		TRANSPORT AND STORAGE	Pag.	5
5		COMMISSIONING AND INCORPORATION ON THE MACHINE	Pag.	6
	5.1	MECHANICAL CONNECTIONS	Pag.	7
	5.2	HYDRAULIC CONNECTION	Pag.	7
	5.3	FIRST STARTUP	Pag.	7
6		FAULT MANAGEMENT AND MAINTENANCE	Pag.	8
	6.1	RADIAL FLEXIBLE COUPLING MAINTENANCE AND REPLACEMENT	Pag.	8
7		END OF LIFE	Pag.	9
8		USEFUL TIPS	Pag.	10

2 FIELD OF APPLICATION

2.1 DESCRIPTION

The following instructions refer to items: **120029103***

This items are classified as partly completed machinery in accordance with directive 2006/42/CE.

2.2 COMPONENTS

- HYDRAULIC GEAR MOTOR WITH TRANSMISSION COUPLING: Displacement 2,6cc/R – Hydraulic flow required 16l/min – ΔP to motor 95bar supplied
- MOTOR HOUSING: made of thermoplastic material: >PC/ABS-GF<
- Ø310 IMPELLER WITH HUB: made of thermoplastic material: >PA66+PA6I/X-GF<
- INLET HOUSING: made of thermoplastic material: >PC/ABS-GF<
- SUPPORT BRACKET: made of galvanized steel
- FLUX REGULATOR VALVE: made of aluminum, designed to limit the inlet flow to 16l/min and to avoid abrupt stop of the impeller
- INLET/OUTLET CONNECTING PIPES
- SILENT BLOCKS: made of NBR rubber

2.3 INTENDED USE

The centrifugal blower is intended to be incorporated into industrial machinery/plant with the function of blowing air taken from the surrounding environment onto materials needing to be cleaned, dried, cooled, separated.

ANY OTHER USE IS OUTSIDE THE MANUFACTURER'S RESPONSABILITY.

This blower is classified as partly completed machinery and must not be put into operation until the final machine which it is to be incorporated has been declared complaint with the provisions of directive 2006/42/CE. The use of an accessory such as pipes, diffusers or other at the airflow outlet section is recommended.

2.4 OPERATING LIMITS

- This centrifugal blower must not be used for blowing air which is toxic, saturated, corrosive or flammable, contains abrasive particles not originating from the ceramic environment, or is at a temperature outside the range -20°C / +60°C;
- Operation up to max. 4000RPM is possible (see sticker on inlet housing).
Actual RPM fluctuations up to 10% are possible, depending on volumetric efficiency of the motor;
- Use as a suction device is possible only in the presence of air free and/or previously purified of abrasive particles.

POLYMER	PC/ABS-GF			PA66-GF		
THERMAL PROPERTIES	-20°C/+90°C			-30°C/+110°C		
CHEMICAL PROPERTIES	A	B	I	A	B	I
	+	+	-	-	+	++

A=ACIDS; B=BASES; I=HYDROCARBONS;
- POOR; + GOOD; ++ VERY GOOD

2.5 PROHIBITED USE

- Do not use to suck liquids and/or solids in the absence of purification upstream of the blower;
- Do not use in areas with a potentially explosive atmosphere;
- Do not put implements in the inlet mouth, and limbs in the outlet when the blower is operating;
- Do not carry out maintenance or other operations with the motor powered and/or the impeller moving.

2.6 SAFETY

ZONE	HAZARD	CAUTIONS
Suction	Capture of objects (e.g. paper, leaves, rags ecc.)	Not to approach at suction grid rags or other objects that could be captured.
Discahrge outlet	Ejection of object/debris captured by suction inlet, contact with moving impeller.	Connect always a diffuser/tube/air knife at the discharge outlet. In case of occasional free outlet functioning, avoid to stay along tha path of the air flow.
Impeller	Failures/contacts with the carters caused by excessive centrifugal force.	Do not exceed the RPM/frequency (4000 RPM/16l/min) indicated on the inlet casing of the Green Blow.
Carter	Shipping failures	Incorporate the blower into the machine after transporting the machine to the place of use.

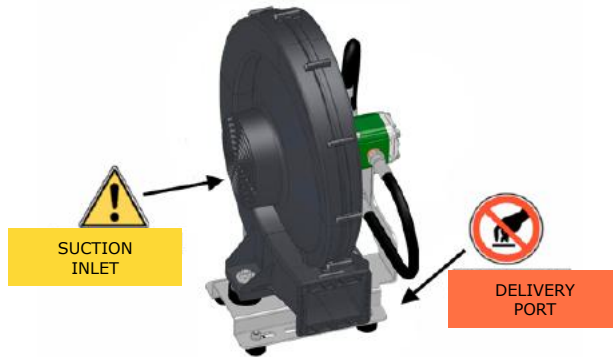

FIGURE 1

3 TECHNICAL FEATURES

The blower is supplied in a single configuration comprising bracket, limiting valve, connection pipes between the valve and the motor and silent blocks. The inlet section of the regulating valve ("IN", figure 2) must be connected with a 3/8" thread and the outlet section of the regulating valve (" OUT ", figure 2) with a 1/2" thread.

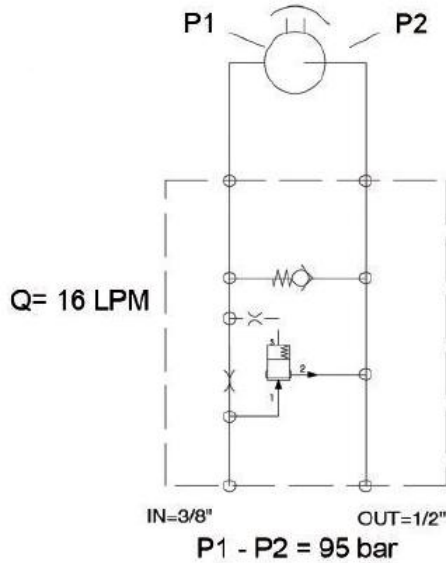

FIGURE 2

4 TRANSPORT AND STORAGE

On arrival, check that the packaging and contents are not damaged. In the event of damage, contact the supplier. A single item can be moved by hand, but multiple items must be handled using appropriate equipment according to the volume and weight of the packaging. Dispose of packaging materials properly.

5 COMMISSIONING AND INCORPORATION OF THE MACHINE

MODIFICATIONS AND CUSTOMIZATIONS ARE NOT PERMITTED IF THESE ARE LIABLE TO AFFECT THE INTEGRITY OF THE BLOWER.

5.1 MECHANICAL CONNECTIONS

1. Fix the blower to a system/machine using suitable M8 nuts and bolts (not supplied) (FIGURE 3);
2. Secure the diffuser (or other accessory) to the outlet using n°4 M6 hex head bolts UNI EN 24017, n°4 M6 nuts UNI EN 24032, n°8 Ø6 washers UNI 6592 (bolts supplied with diffusers). Tighten the screws with a maximum torque of 8Nm (FIGURA 4);
3. Insert a possible filter (codes 200353, 200354, 200355) on the inlet mouth, fixing it using the fastening belt (supplied with the filter) (FIGURE 5).

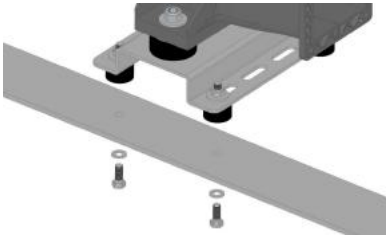

FIGURE 3

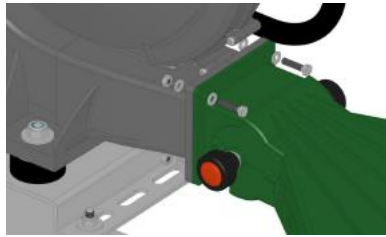

FIGURE 4



FIGURE 5

5.2 HYDRAULIC CONNECTION

1. Connect the "IN" inlet port with 3/8" thread of the flow regulating valve to the inlet pipe (FIGURE 6);
2. Connect the "OUT" inlet port with 1/2" thread of the flow regulating valve to the outlet pipe (FIGURE 6).

Attention! Avoid reductions, bottlenecks, valves, etc. and excess lengths of the exhaust pipe (max length 2m)

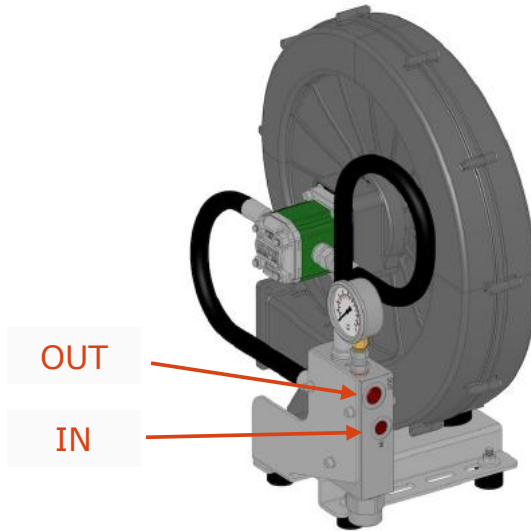

FIGURE 6

5.3 FIRST STARTUP

1. Do not start the machine-system without having secured the blower;
2. Test blower operation, checking that the impeller rotates in the direction indicated by the arrows on the casing;
3. Verify that the blower, once incorporated to the machine-system, does not have abnormal vibrations during operation.
If not, check that all the components have been assembled correctly.
4. Check the exhaust pressure indicated by the pressure gauge (supplied): max limit 5 bar. Exceeding this value causes the engine seals to fail.
If necessary, also limit the oil flow rate to 20L/min max.

6 FAULT MANAGEMENT AND MAINTENANCE

During maintenance/cleaning, use specific PPE for arm protection.

Components functionality	<p>At monthly intervals check that all bolts and screws are perfectly tightened and that plastic parts do not show signs of damage or deterioration: if they do, consider replacing them to restore the necessary conditions of safety. Carefully look after all fixing bolts and screws during maintenance work with the plant stopped and refit them (as described in the installation procedure) before restarting the plant/machine.</p> <p>If bolts or screws are missing, new ones must be used.</p>
Cleaning	<p>At monthly intervals check the cleaning of all components, in particular of the impeller.</p> <p>Cleaning operations must be performed strictly with the machine turned off and after the impeller has come to a standstill.</p> <p>It is possible to use a wet cloth to clean the external surfaces and (after removing the diffuser/tube) the internal surfaces.</p>
Filter checking	<p>At weekly intervals check the state of the suction filter.</p> <p>In case of excessive dirt of the filter cause a reduction of the performances, clean or replace the filter.</p>

6.1 RADIAL FLEXIBLE COUPLING MAINTENANCE AND REPLACEMENT

Every 300 hours of operation, and/or in case of increased noise level, inspect the radial joint (code 102382) for wear following the instructions below:

- Undo the four M6 cap screws securing the motor and remove it axially (FIGURE 7);
- Remove and inspect the flexible coupling (FIGURE 8). Replace it in case of obvious wear;
- Reassemble the motor and tighten the fixing screws, applying medium strength threadlocker (FIGURE 9).

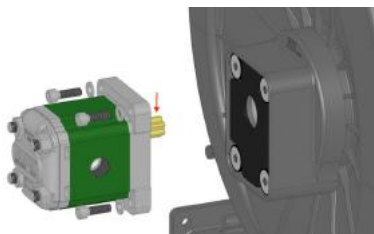

FIGURE 7

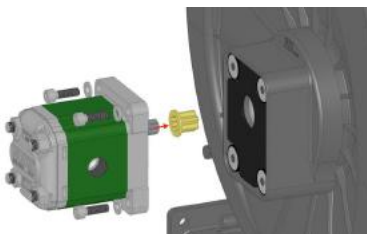

FIGURE 8

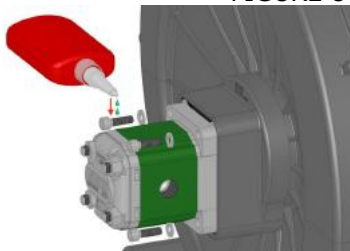

FIGURE 9

7 END-OF-LIFE

The materials used by FM Partec, whether plastic or metal, must be treated as special waste and therefore should not be released into the environment.

<p>Disassembly</p>	<p>In order to separate motor, plastic material and metal parts, follow in reverse the assembly instructions.</p>
<p>Disposal</p>	<p>Refer to the legislation in force in the country of employment.</p>

8 USEFUL TIPS

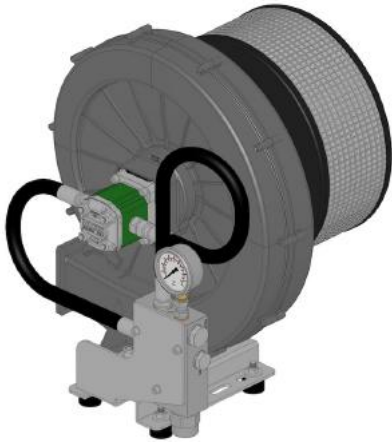

TUBES DIA

OUTLET:

- Thread 1/2"
- Minimum tu

INLET:

- Thread 3/8"
- Minimum tu

FIGURE 10

MECHANICALS CONNECTIONS

Cylindrical coupling 100M
(cod. 102519/A)

Fastening band 100
(cod. 200331)

Flexible tube 100 F/F
(cod. 200704)

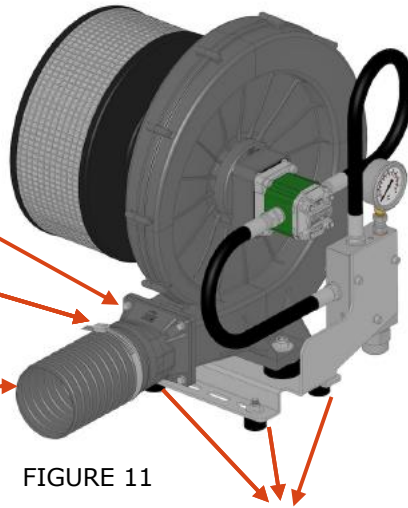

FIGURE 11

USE JOINT OR FLEXIBLE TUBE

DO NOT REMOVE SILENT-BLOCKS !

ASPIRATION FILTER



FIGURE 12

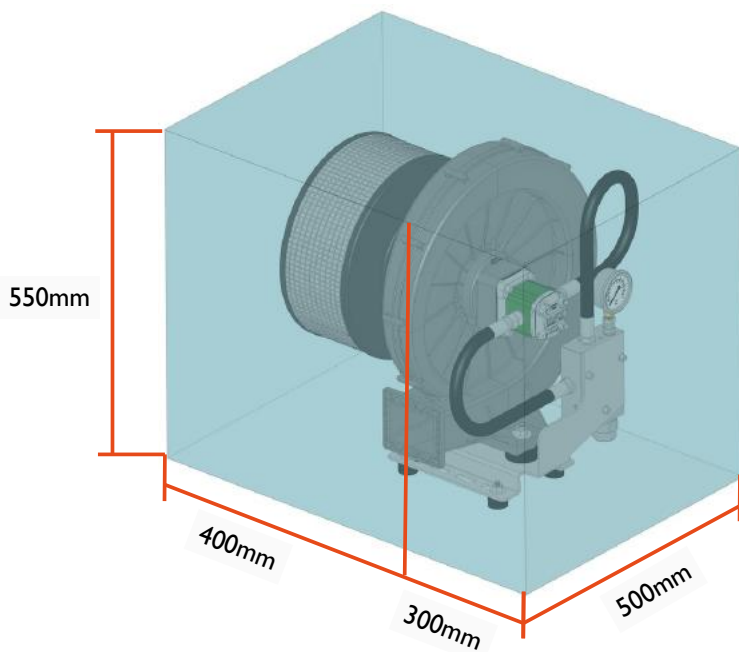

FIGURE 13