

FM PARTEC®

FM Partec S.p.A. - Via Europa 4 - Correggio (RE) ITALY
Tel (+39) 0522 631055 - info@fmpartec.com

CONNECTIONS AND SETTING MANUAL



INVERTER ME300 for GREENBLOW IE3, PLUS & 5K

GREENBLOW®

USING INSTRUCTION WITH BLOWERS GREENBLOW IE3, PLUS AND 5K

(ENGLISH TRANSLATION)

PRODUCT: INVERTER DELTA ME300

Read the instructions completely and keep them for future reference, referring to the FM Partec technical specifications contained in the catalogue.

If you are not in possession of these specifications, please ask for them to be provided.

1 TABLE OF CONTENTS AND INTERPRETATION OF SYMBOLS

1		TABLE OF CONTENTS AND INTERPRETATION OF SYMBOLS	Pag.	1
2		FIELD OF APPLICATION	Pag.	2
3		USING TIPS INVERTER WITH BLOWER GREEN BLOW PLUS AND GREEN BLOW IE3	Pag.	3
	3,1	MANUAL DRIVE	Pag.	5
	3,2	AUTOMATIC DRIVE	Pag.	8
	3,3	PARALLEL DRIVE OF MULTIPLE INVERTERS	Pag.	12

		
WARNING	DANGER	DANGER Electrocution risk

2 FIELD OF APPLICATION

These instructions concern the article:

cod. 200366PLUS, 200366IE3 – Inverter DELTA model ME300 2.2kW

cod. 200518-5K – Inverter DELTA model ME300 3.7kW

and concern exclusively the use of this device to operate the blower Green Blow IE3 cod. 1200029003*, Green Blow Plus cod. 1200029004*, Green Blow 5K cod. 120029007*.



With regard to health, safety, correct installation, maintenance and disposal, please consult the instruction manual of your inverter supplier.

The inverters are supplied appropriately programmed and protected by a password, so that do not require auto-tuning functions and/or other parameter changes.

The programming of the inverters has been optimized to limit noise and vibrations, **so it is strongly discouraged to reset the factory parameter of the inverter**, because the sole auto-tuning function is not sufficient for using the blower.



N.B. IN CASE OF PARAMETERS RESET AND/OR PASSWORD SUPPLYING, WARRANTY BECOMES NULL AND VOID.

To avoid malfunction and/or damage to the inverter:



- Refer to the inverter instruction manual;
- Avoid direct exposure to sunlight;
- Use shielded cables with a max. length of 25m.

3 USING TIPS INVERTER WITH GREEN BLOW IE3, PLUS AND 5K

Inverters ME300 VFD5A5ME43AFSAA e VFD9A0ME43AFSAA (frame C2) are inverters with IP20 protection rate equipped with a cooling fan and are intended for insertion inside a distribution board.

The supplied programming provides the possibility of either manual (via keypad with integrated potentiometer, FIGURE 1 lh) or automatic drive via external sensor/switch/PLC with PNP or NPN connection.

As default, the inverter are supplied with connections corresponding to PNP manual drive.



FIGURE 1

In order to make the electrical connections, it is necessary to remove the external cover of the inverter by unscrewing the 2 joints highlighted in FIGURE 1 (rh).

FIGURE 2 and the following table show the terminals to be used for the power supply, the motor and the grounding connections. For any type of connection it is essential to be sure that the terminal screws are fully tightened.



Make sure to operate always with NO VOLTAGE.

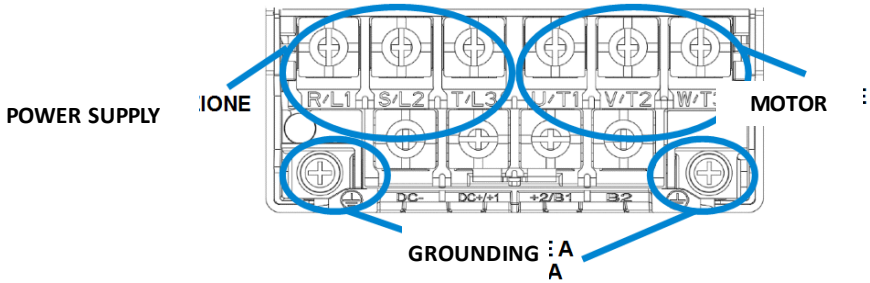

FIGURE 2

Motor connection	Terminals U/T1, V/T2, W/T3 + grounding
Power supply connection	Terminals R/L1, S/L2, T/L3 + grounding

FIGURE 3 shows a scheme of the whole terminal block of the inverter.

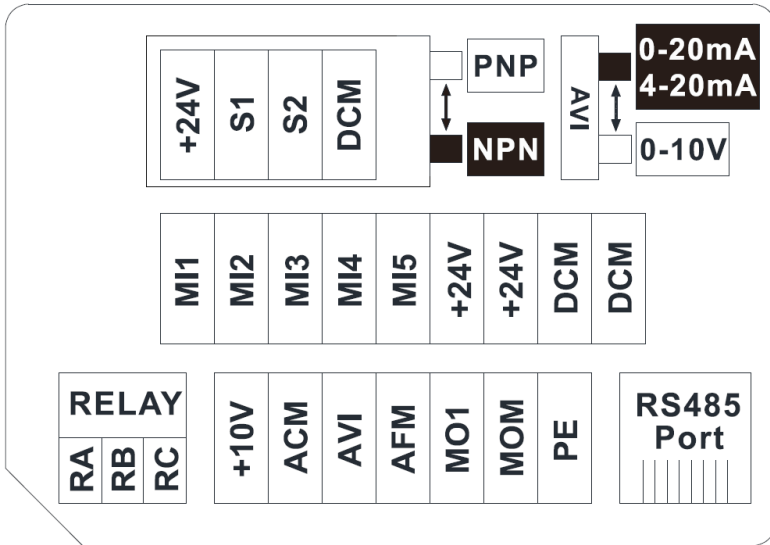

FIGURE 3



If more blowers are connected to a single inverter (this layout is available only with Green Blow IE3, cod.*), it is advisable to install 1 magnetothermic switch for each blower.

For any further information, refer to the inverter use and maintenance.

3.1 MANUAL DRIVE



In order to make the manual drive, it is necessary to make the connections as shown in FIGURE 4, **after removing the electric tension.**



As default, the inverter are supplied with connections corresponding to PNP manual drive with integrated potentiometer (FIGURE 4).

Once made the connections, apply the external cover before switch on the inverter.

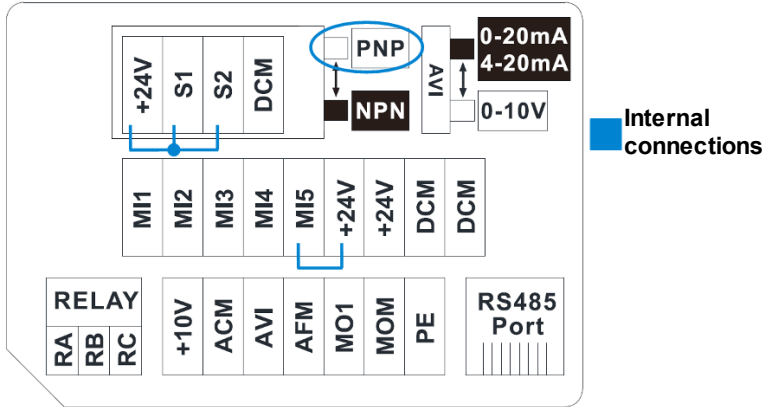

FIGURE 4: manual drive - PNP connection - integrated potentiometer (default).

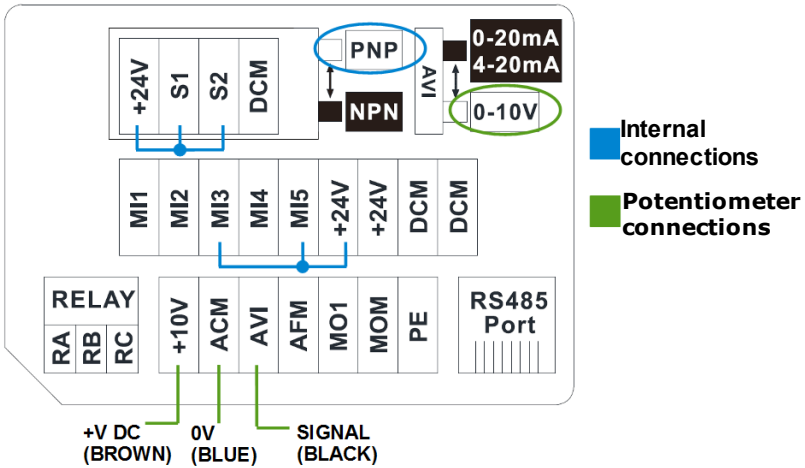

FIGURE 5: automatic drive - PNP connection - external potentiometer.

Once switched on the inverter, the display will show the setted frequency (FIGURE 6 lh). Pressing the "MODE" button it is possible to display the current frequency (FIGURE 6 rh) and the adsorbtion of electrical current in Amperre (FIGURE 7).



FIGURE 6



FIGURE 7

BUTTON	DESCRIPTION
RUN	Switch on of the blower
STOP/RESET	Switch off of the blower and alarm reset
MODE	Display current frequency and adsorbtion in Ampere

The following table shows the functions usable in manual drive.

FUNCTION	CHARACTERISTICS
Frequency change	Maximum and default value 225Hz / 4500 RPM (GB PLUS) and 65Hz / 3600RPM (GB IE3). In order to change the value use the integrated potentiometer (default connection) or an external potentiometer (connection shown in FIGURE 5).
Acceleration and deceleration ramps change	Default values equal to 10s, unchangeable

For any further information, refer to the inverter use and maintenance manual.

3.2 AUTOMATIC DRIVE



In order to make the automatic drive, by switch, it is necessary to make the connections as shown in FIGURE 8 and FIGURE 9, **after removing the electric tension.**



In the case of sensor that require power supply (e.g. photocells), it is necessary to make the connections as shown in FIGURE 10,11,12,13 **after removing the electric tension.**



Once made the connections, apply the external cover before switch on the inverter.

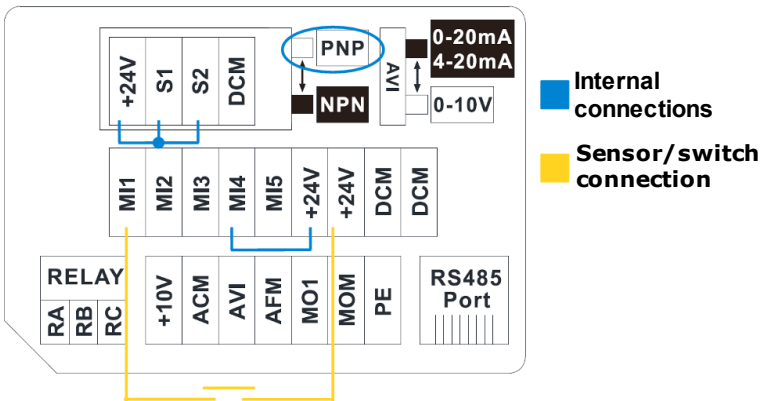

FIGURE 8: automatic drive switch/PLC – PNP connection – integrated potentiometer.

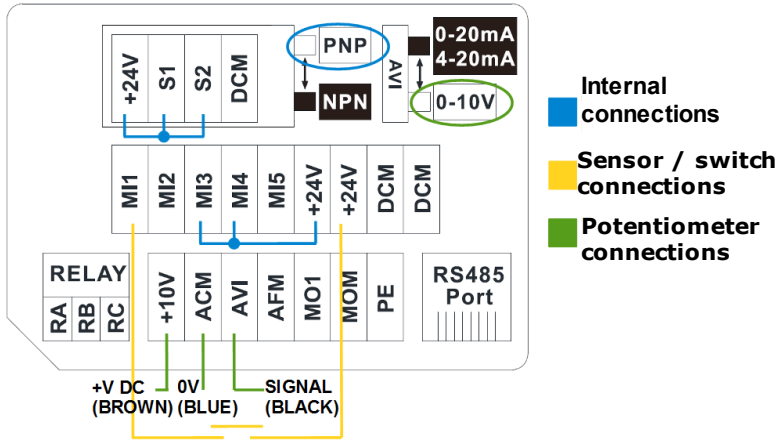

FIGURE 9: automatic drive switch/PLC – PNP connection – external potentiometer.

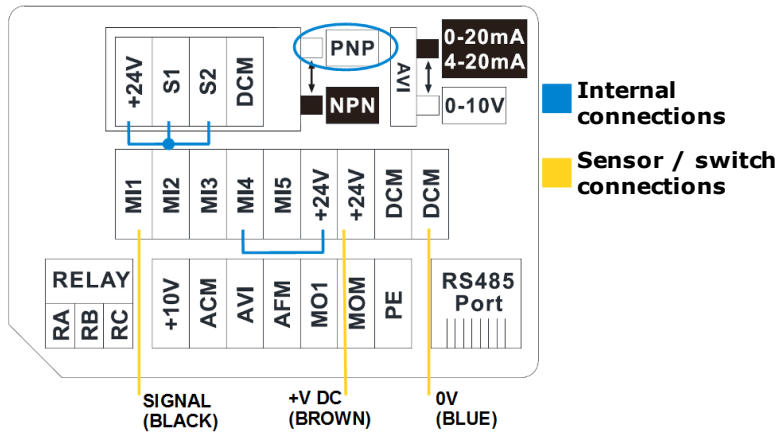

FIGURE 10: automatic drive powered sensor/photocell – PNP connection – integrated potentiometer.

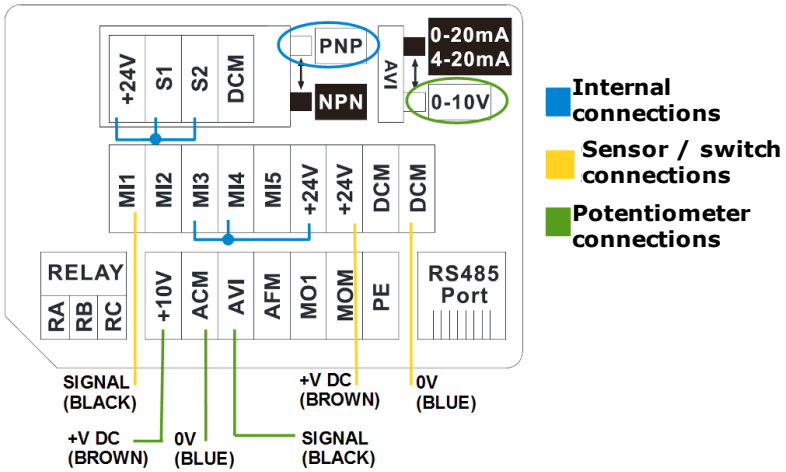

FIGURE 11: automatic drive powered sensor/photocell – PNP connection – external potentiometer.

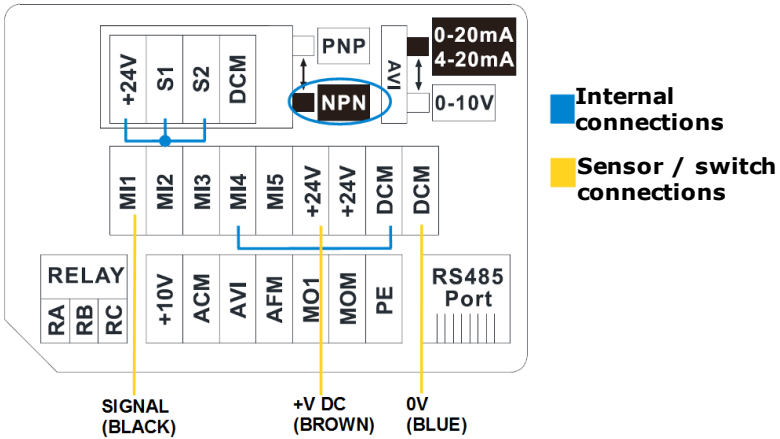

FIGURE 12: automatic drive powered sensor/photocell – NPN connection – integrated potentiometer.

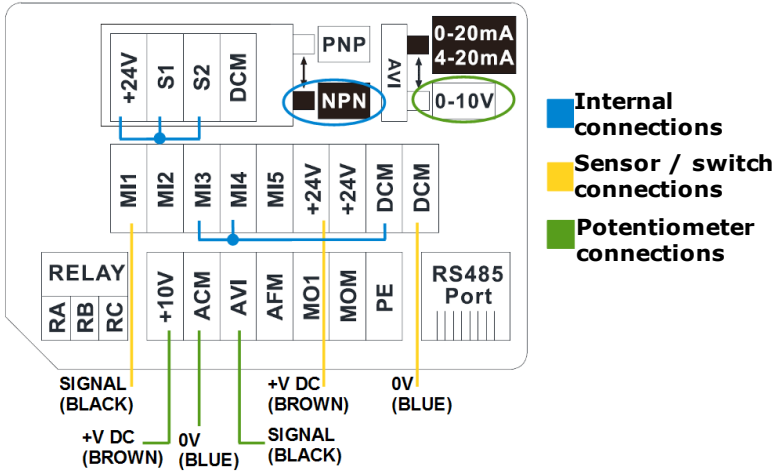

FIGURE 13: automatic drive powered sensor/photocell – NPN connection – external potentiometer.

Once switched on the inverter, the display will show the setted frequency (FIGURE 14 lh). Pressing the “MODE” button it is possible to display the current frequency (FIGURE 14 rh) and the adsorbtion of electrical current in Ampere (FIGURE 15).



FIGURE 14



FIGURE 15

BUTTON	DESCRIPTION
STOP/RESET	Switch off of the blower and alarm reset
MODE	Display current frequency and adsorbtion in Ampere

The following table shows the functions usable in automatic drive.

FUNCTION	CHARACTERISTICS
Frequency change	Maximum and default value 225Hz / 4500 RPM (GB PLUS) and 65Hz / 3600RPM (GB IE3). In order to change the value use the integrated potentiometer (connections in FIGURE 8, 10 ,12) or an external potentiometer (connections in FIGURE 9, 11, 13).
Acceleration and deceleration ramps change	Default values equal to 10s, unchangeable

For any further information, refer to the inverter use and maintenance manual.

3.3 PARALLEL DRIVE OF MULTIPLE INVERTERS

It is possible to drive automatically more inverters in parallel, connecting them to PNP/NPN sensor (FIGURE 16, 18) or to an external potentiometer (FIGURE 17, 19).



One of the inverter connected in parallel will be the "master" and only to this inveter the power supply of the sensor (+24V) and/or potentiometer (+10V) will be connected.

All the other inverters will have not to present the connection to the power supply. FIGURE 16, 17, 18, 19 show the connections necessary to parallel drive of 2 or more inverters (inverter #1 is the one with the "master" connection).

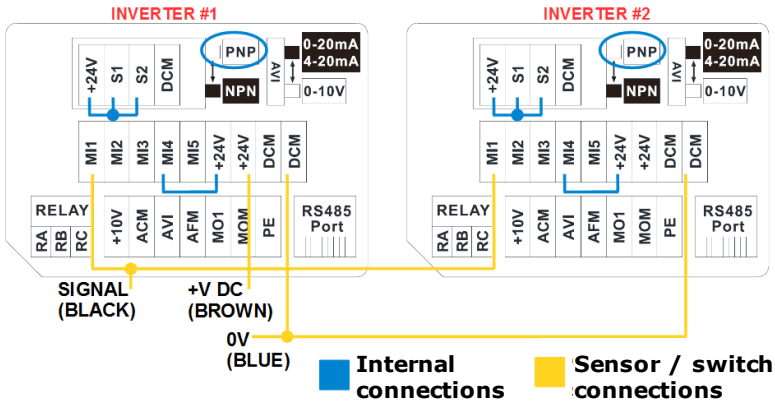

FIGURE 16: automatic parallel drive powered sensor/photocell – PNP connection – integrated potentiometer.

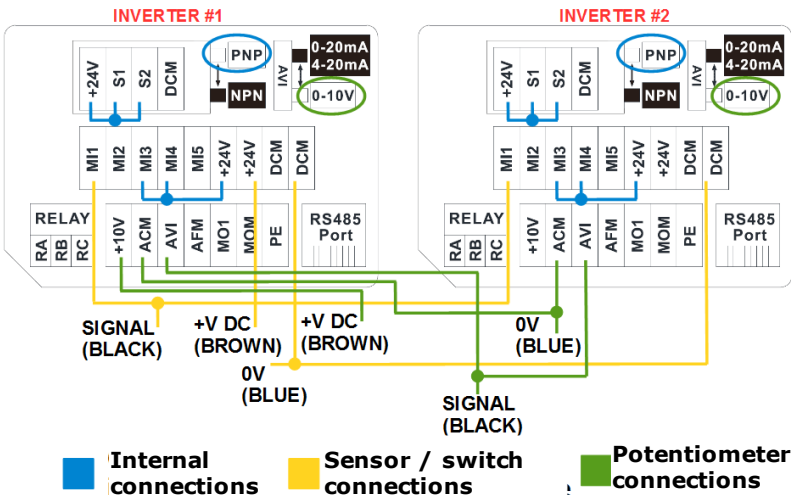

FIGURE 17: automatic parallel drive powered sensor/photocell – PNP connection – external potentiometer.

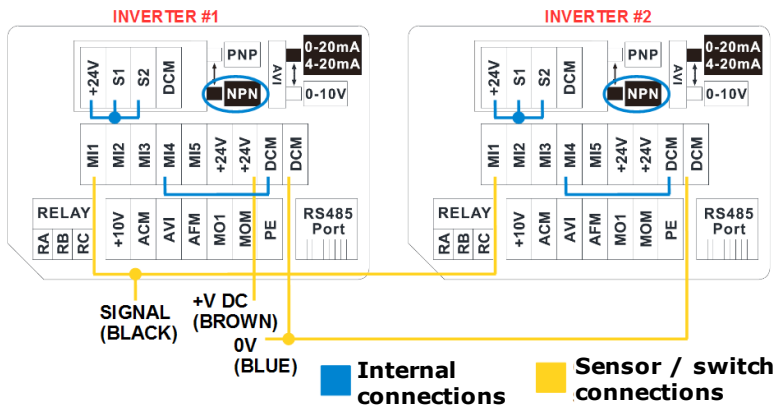

FIGURE 18: automatic parallel drive powered sensor/photocell – NPN connection – integrated potentiometer.

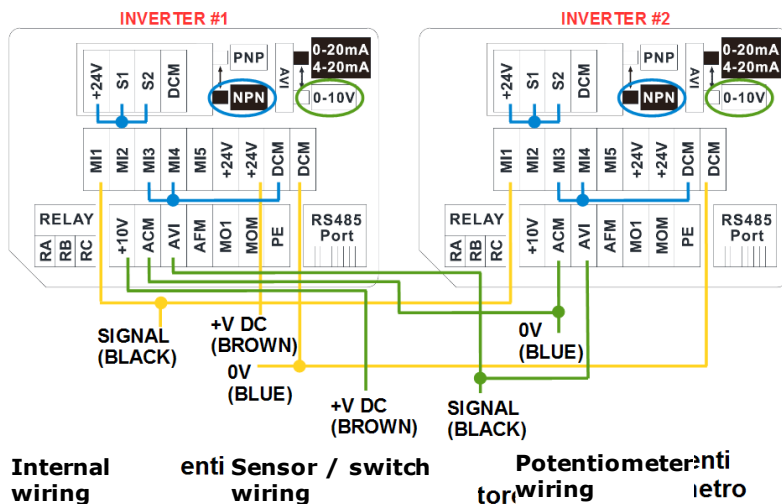

FIGURE 19: automatic parallel drive powered sensor/photocell – NPN connection – external potentiometer.