

# FM PARTEC®

FM Partec S.p.A. - Via Europa 4 - Correggio (RE) Italy  
Tel (+39) 0522 631055 - info@fmpartec.com

## INSTRUCTIONS AND USER MANUAL

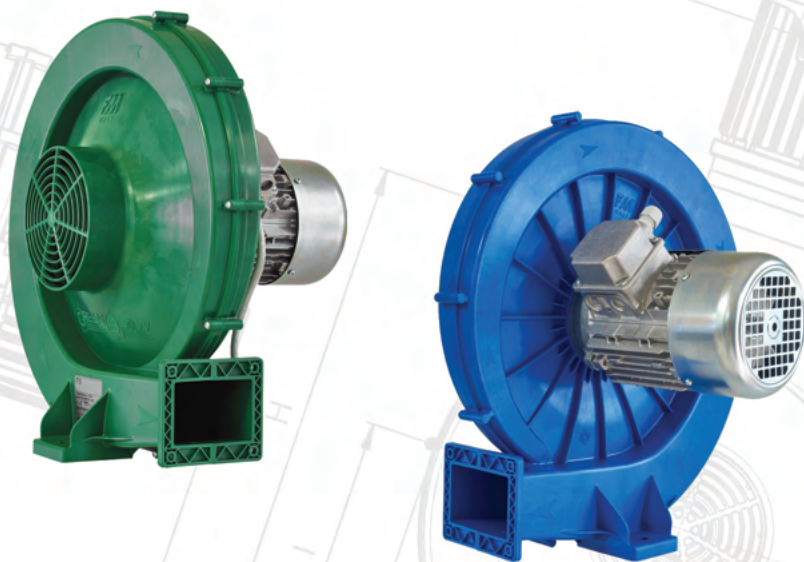

### GREENBLOW STANDARD AND GREENBLOW IE3

GREENBLOW®

# ASSEMBLY INSTRUCTIONS

## (ORIGINAL VERSION IN ITALIAN)

**PRODUCT: GREEN BLOW STANDARD & GREEN BLOW IE3**

Read the instructions carefully and keep them for the future reference, referring to the FM Partec technical specifications contained in the catalogue. If you are not in possession of these specifications, please ask for them to be provided.

### 1 TABLE OF CONTENTS AND SYMBOLS INTERPRETATION

<b>1</b>	<b>TABLE OF CONTENTS &amp; SYMBOLS INTERPRETATION</b>	Pag.	1
<b>2</b>	<b>FIELD OF APPLICATION</b>	Pag.	2
	2.1 DESCRIPTION	Pag.	2
	2.2 COMPONENTS	Pag.	2
	2.3 INTENDED USE	Pag.	2
	2.4 OPERATING LIMITS	Pag.	4
	2.5 PROHIBITED USE	Pag.	4
	2.6 SAFETY	Pag.	5
<b>3</b>	<b>TECHNICAL CHARACTERISTICS</b>	Pag.	6
<b>4</b>	<b>BLOWER COMPONENT ASSEMBLY INSTRUCTIONS</b>	Pag.	6
<b>5</b>	<b>TRANSPORT AND STORAGE</b>	Pag.	7
<b>6</b>	<b>COMMISSIONING AND INCORPORATION ON THE MACHINE</b>	Pag.	8
	6.1 MECHANICAL CONNECTIONS	Pag.	8
	6.2 ELECTRICAL CONNECTION	Pag.	9
	6.3 FIRS STARTUP	Pag.	9
<b>7</b>	<b>MAINTENANCE</b>	Pag.	10
<b>8</b>	<b>FAULT MANAGEMENT</b>	Pag.	11
<b>9</b>	<b>END OF LIFE</b>	Pag.	11



**WARNING**



**DANGER**



**DANGER**  
**Electrocution Risk**

## 2 FIELD OF APPLICATION

### 2.1 DESCRIPTION

The following instructions refer to items:

**120029001\*, 120029002\*, 120029008\*,  
120029003\*, 120029009\***

These items are classified as partly completed machinery in accordance with directive 2006/42/CE.

### 2.2 COMPONENTS

• <i>SINGLE-SPEED THREE-PHASE ASYNCHRONOUS MOTOR</i>						
	Power (kW)	Voltage (V)	Frequency (Hz)	Poles °N	Connections	Certifications
120029001*	0,37	230/400	50	2	B14	CE
120029002*	0,45	220/380	60	2	B14	CE
120029003*	0,37	230/400	50	2	B14	CE
120029008*	0,45	277/480	60	2	B14	CE, UL, CSA
120029009*	0,45	220/380	60	2	B14	CE, UL, CSA

- *MOTOR HOUSING:*  
made of thermoplastic material: >ABS-GF<  
>PC/ABS-GF<
- *Ø310 IMPELLER WITH HUB:*  
made of thermoplastic material: >PA66-GF<  
>PA66+PA6I/X GF<
- *INLET HOUSING:*  
made of thermoplastic materials: >ABS-GF<  
>PC/ABS-GF<

### 2.3 INTENDED USE

The centrifugal blower is intended to be incorporated into industrial machinery/plant with the function of blowing air taken from the surrounding environment onto materials needing to be cleaned, separated, dried or cooled.



**ANY OTHER USE IS OUTSIDE THE  
MANUFACTURER'S RESPONSABILITY.**

This blower is classified as partly completed machinery and must not be put into operation until the final machine into which it is to be incorporated has been declared compliant with the provisions of directive 2006/42/EC.

The use of an accessory such as tubes, couplings, diffusers or other at the airflow outlet section is recommended.

## 2.4 OPERATING LIMITS

- Make sure that the rated current (A) does not exceed the value shown on the electric motor data plate;
- This centrifugal blower must not be used for blowing air which is toxic, saturated with vapour, corrosive or flammable, contains abrasive particles not originating from the ceramic environment, or is at a temperature outside the range -20°C / +60°C;
- It is possible to use it at higher power frequencies via inverters up to a maximum of:
  - 60Hz/3400RPM (Green Blow Standard – 120029001\*-120029002\*-120029008\*),
  - 65Hz/3600RPM (Green Blow IE3 – 120029003\* - 120029009\*));
- Cod. 120029002\*, 120029008\* carry a default frequency of 60Hz/3400RPM;
- Use as a suction device is possible only in the presence of air free of abrasive particles, for example by a cyclone separator.

POLYMER	ABS-GF			PA66-GF		
<b>THERMAL PROPERTIES</b>	-20°C/+80°C			-30°C/+110°C		
<b>CHEMICAL PROPERTIES</b>	<b>A</b>	<b>B</b>	<b>I</b>	<b>A</b>	<b>B</b>	<b>I</b>
	+	+	-	-	+	++

A=ACIDS; B=BASES; I=HYDROCARBONS;  
- POOR; + GOOD; ++ VERY GOOD

## 2.5 PROHIBITED USE



- Do not use to suck liquids and/or solids;
- Do not use in areas with a potentially explosive atmosphere;
- Do not put tools in the inlet mouth, and limbs in the outlet when the blower is operating;
- Do not carry out maintenance or other operations with the motor powered and/or the impeller moving.

## 2.6 SAFETY





<b>ZONE</b>	<b>HAZARD</b>	<b>CAUTIONS</b>
Inlet 	 Capture of objects (e.g. paper, rags ecc.)	Not to approach at suction grid rags or other objects that could be captured.
Discharge outlet	 Ejection of objects/debris sucked by discharge inlet, contact with the moving impeller.	Connect always a diffuser/tube/air knife at the discharge outlet. In case of occasional free outlet functioning, avoid to stay along the path of the air flow.
Terminal box	Electrocution	Do not operate in presence of electric tension.
Impeller	 Failures/contacts with the carters caused by excessive centrifugal force.	Do not exceed RPM/maximum frequency (3400RPM/60Hz, 3600RPM/65Hz) indicated on the sticker placed on the inlet casing.
Carter	Shipping failures	Incorporate the blower into the machine after transporting the machine to the place of use.



FIGURE 1

### 3 THECNICAL CHARACTERISTICS

In the lower part of the inlet casing, the blower has a sticker giving the efficiency data (FIGURE 2).

For more data, refer to the plate on the electric motor.

FM PARTEC®	
Overall efficiency (50Hz, current from electricity grid, no inverter)	0,5
Measurement category	B
Efficiency category	Total
Efficiency grade N	64

FIGURE 2

### 4 BLOWER COMPONENT ASSEMBLY INSTRUCTIONS

**NB:** Although the blower components have been specifically designed to minimise the risk of assembly errors, the following instructions must be observed scrupulously.

1. Secure the electric motor to the motor housing and fasten with n°4 low cylinder-head M6x20 screws UNI 9327 (bolts supplied) with a max. torque of 8Nm (FIGURE 3);
2. Secure the Ø310 impeller to the electric motor shaft using n°1 M5 socket head cap screw UNI 5931 and washer UNI 6593 (bolts supplied). Tighten to a max. torque of 8Nm. We recommend using thread lock on the screw for more effective locking (Loctite 270 or similar) (FIGURE 4);
3. Secure the inlet housing to the previously assembled group using n°12 KC40 x 30 screws (bolts supplied). Tighten the screws to a max. torque of 5Nm (FIGURE 5).

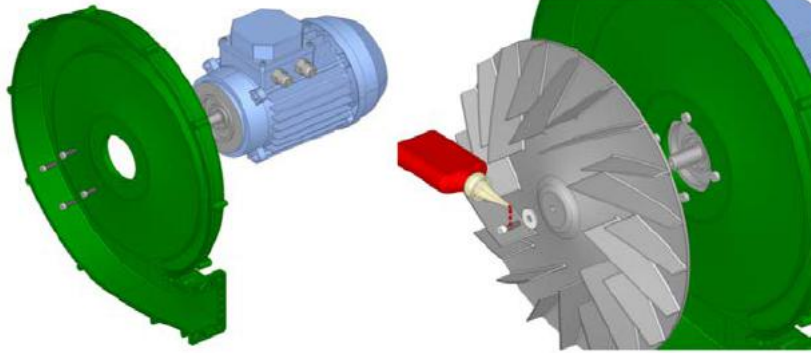

FIGURE 3

FIGURE 4

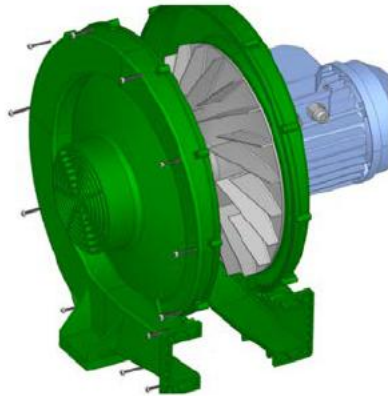

FIGURE 5

## **5 TRANSPORT AND STORAGE**

On arrival, check that the packaging and contents are not damaged. In event of damage, contact the supplier. A single item can be moved by hand, but multiple items must be handled using appropriate equipment according to the volume and weight of the packaging.

Dispose of packaging materials properly.

## 6 COMMISSIONING AND INCORPORATION OF THE MACHINE



**MODIFICATIONS AND CUSTOMISATIONS ARE NOT PERMITTED IF THESE ARE LIABLE TO AFFECT THE INTEGRITY OF THE BLOWER.**

### 6.1 MECHANICAL CONNECTIONS

1. Secure the blower to a plant/machine using M10 bolts (not supplied).  
We recommend the use of a washer of appropriate size (FIGURE 6);
2. Secure the diffuser (or other accessory) to the outlet section using n°4 M6 hex head bolts UNI EN 24017, n°4 M6 nuts UNI EN 24032, n°8 Ø6 washers UNI 6592 (bolts supplied with the diffusers).  
Tighten to a max. torque of 8Nm (FIGURE 7);
3. Insert the possible filter on the inlet section, fixing it using the fastening band (supplied with the filter) (FIGURE 8).

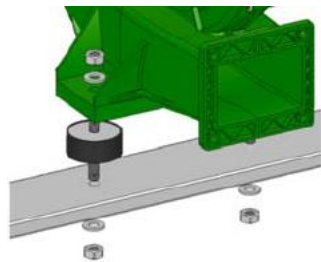

FIGURE 6

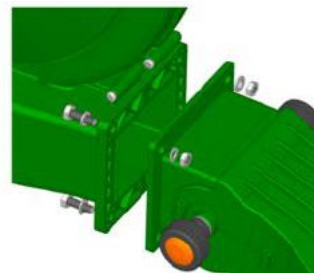

FIGURE 7



FIGURE 8

## 6.2 ELECTRIC CONNECTIONS

Make the electrical connections to the diagram provided inside the motor's terminal box (FIGURE 9).

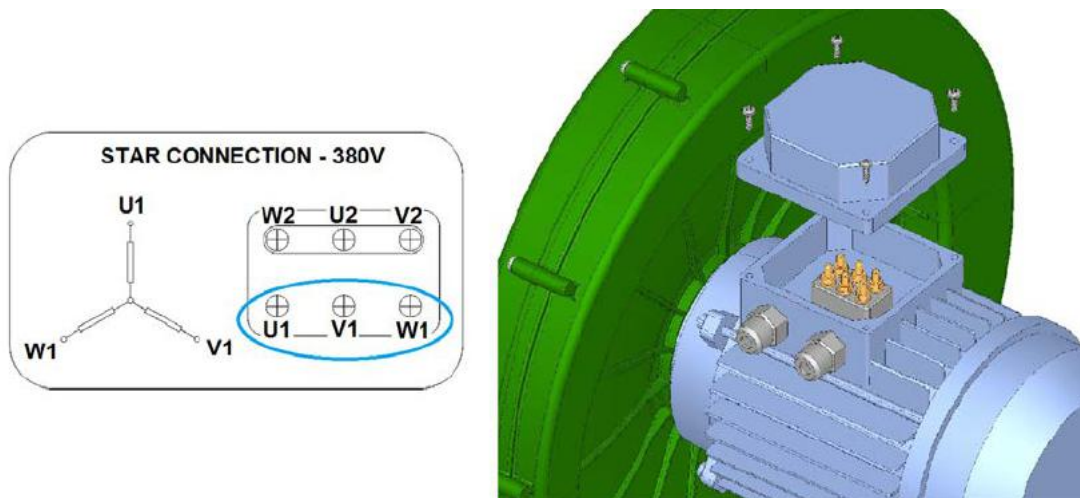

FIGURE 9

## 6.3 FIRST STARTUP

- Do not start the machine/system without having secured the blower;
- Test blower operation, checking that the impeller rotates in the direction indicated by the arrows on the casing; If the rotation direction is incorrect, appropriately modify the electrical connection by inverting the phases inside the terminal block;
- Once incorporated into the machine, check that the blower does not vibrate abnormally during operation; Otherwise, make sure all components have been assembled correctly;
- If more blowers are connected to a single inverter, it is advisable to install 1 magnetothermic switch for each blower.

## 7 MAINTENANCE

During maintenance/cleaning, use specific PPE for arm protection.

<b>Components functionality</b>	<p>At monthly intervals check that all bolts and screws are tight and that plastic parts do not show signs of damage or deterioration: if they do, consider replacing them to restore the necessary conditions of safety.</p> <p>Carefully look after all fixing bolts and screws during maintenance work with the plant stopped and refit them (as described in the installation procedure) before restarting the plant/machine. If bolts or screws are missing, new ones must be used.</p>
<b>Cleaning</b>	<p>At monthly intervals check the cleaning of all components, in particular of the impeller. Cleaning operations must be performed strictly with the machine turned off and after the impeller has come to a standstill.</p> <p>It is possible to use a wet cloth to clean the external surfaces and (after removing the diffuser/tube) the internal surfaces.</p>
<b>Filters checking</b>	<p>At weekly intervals check the state of the suction filter or use the dedicated function of predictive maintenance available into the CFP2000-CP2000 inverter.</p> <p>In case of excessive dirt of the filter cause a reduction of the performances, clean or replace the filter.</p>

## 8 FAULT MANAGEMENT

In case of malfunction during use, disconnect the power supply and have the cause of the fault checked by professionally qualified personnel.

In case of work requiring partial or complete removal of the above-mentioned centrifugal blower components, make sure the impeller has stopped moving, the blower is disconnected from mains power and that the machine/system is at a standstill.

<b>MALFUNCTIONING</b>	<b>CAUSE AND POSSIBLE SOLUTION</b>
<b>Noisy blower, reduced air speed</b>	Check that the impeller rotates in the direction indicated by the arrows on the inlet casing. If the rotation direction is incorrect, invert 2 phases inside the terminal block.
<b>Failed start-up of 1 of the 2 blowers that supply a single air knife with two inlets.</b>	Not simultaneous operation of the blowers. Operate the blowers <u>at the same time</u> and/or extend the acceleration ramps.

## 9 END OF LIFE

The materials used by FM, whether plastic or metal, must be treated as special waste and therefore should not be released into the environment.

<b>Disassembly</b>	In order to separate motor, plastic material and metal parts, follow in reverse the assembly instructions.
<b>Disposal</b>	Refer to the legislation in force in the country of employment.

**IU012-D24-EN**